

- Over 30 YEARS Supplying Africa -



BirCraft

GEARED MOTORS - LINEAR ACTUATORS - CONTROLS

Website: www.bircraft.co.za Fax: 086 694 5806 E-mail: 01@bircraft.co.za International Tel. +27 11 468 1881 Fax: 011 468 1698
 National Sales: **0861 BIRCRAFT** National Sales: **086 124 7272** Cell: **074 465 1744**
BEE Certified

Permanent Magnets D.C. ELECTRIC MOTORS

Construction	Tubular, without fan
Size	Ø 80 mm
Power	140 W S2 (100 W S1)
Magnets	2
Bearings	Ball Bearings
Mounting Holes	4
Power Supply	Low voltage, 12 or 24 Vdc
Brushes	2 inside brushes made of graphite/copper composite
Brushes Size	L x W x H = 17.1 x 6.5 x 16.7 mm
Frame	Silver colour, satin-finish
Electric Cable	Length: 1000 mm

Approximate service life of the brushes: the rate at which the brushes wear down depends on the work conditions (start-stop frequency, overload conditions). Under conditions of nominal load, good power supply and operation without excessive electric arcs, the service life is approx. 3000 hrs.

Type	Duty S	Pn [W]	V [V]	I [A]	IC	FF	Mn [Nm]	n ₁ [min ⁻¹]	IP	Kg
EC100.120	S1	100	12	12	F	1	0.31	3000	44	2.7
	S2	140		16.8			0.43			
EC100.240	S1	100	24	6			0.31			
	S2	140		8.4			0.43			

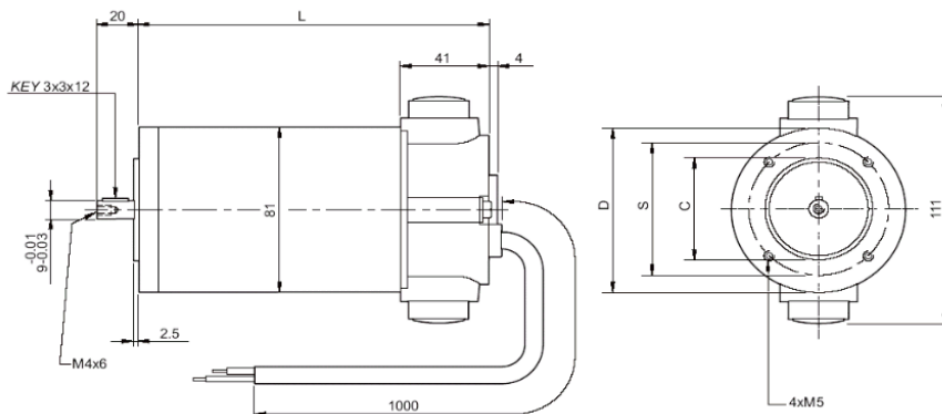

56 B14		63 B14	
L	153	L	155
D	80	D	90
S	65	S	75
C (-0.03/-0.01)	50	C (-0.03/-0.01)	60